

Wheel Loader

JGM 767KV

Tier 2



Operating Weight: 21,000kg

Rated Load: 179kW

Bucket Capacity: 4.5m³

JINLONG 晋工

JINONG 767KV

Wheel Loader

Specifications

Operating weight: 21,000kg

Operating weight includes the work equipment stipulated by manufacturer, the unloaded attachments, driver (75kg), full-filled fuel tank, full-filled radiator, and all fluids (including the hydraulic oil, drive oil, engine oil, and engine coolant) added to the set level stipulated by manufacturer.

Bucket capacity: 3.3-5.5m³

Engine

Description

Emission grade	Tier 2
Manufacturer	Cummins
Model	6LTA A8.9-C240(T2)
Rated engine power	179 kW /2200 RPM

Drive axle

Type	USA Meritor axle
Swinging angle	±10°

Fluid level

Fuel	290 L
Engine oil	24 L
Antifreeze	68 L
Hydraulic oil	290 L
Drive oil	54 L
Drive axle / single	51 L

JINONG

Drive parts

Description

Planetary – type power-assisted transmission from China Hangzhou Advance Gearbox Co., Ltd., single-stage four-element twin-turbo hydraulic torque converter features less gears, large traction force and is in good match with engine and transmission(ZF technology); Feicheng Yunyu 60 drive axle.

Power - train type	Drive axle
	Power gear-shifting
Torque converter	Single- stage
	Four elements
Max. traveling speed, forward	37 km/h
Max. traveling speed, backward	17 km/h
Gears, forward	2
Gears, backward	1

Hydraulic system

Description

This hydraulic system is of dual-pump confluence and steering - prevailing type, featuring the high efficiency and low fuel consumption.

Full hydraulic coaxial flow steering amplification system, with light and flexible steering and reliable operation;

High-precision paper filter element is used for oil suction and return of hydraulic oil tank to ensure the cleanliness of hydraulic system;

High-standard in the industry and new technology hydraulic components to improve the reliability of hydraulic system.

Work pump type	Gear pump
System pressure	18 MPa
Lifting duration	6.5 s
Unloading duration	1.6 s
Lowering duration	3.6 s
Sum of three durations	<12 s
Control type	Joystick control

Brake

Description

Full-hydraulic dual-pipeline disc brake system; three pliers on one wheel; parking brake being of cable-controlled disc brake; main brake elements are exported and of high quality, making a braking safer and more reliable.

Type of service brake	Disc brake
Type of service brake	Hydraulic – pliers disc type
Type of parking brake	Clamp type brake
Type of parking brake	Cable control

Control type

Description

Steering system: articulated steering by steering wheel
System supply: full-hydraulic coaxial flow-amplification steering system, flexible and easy steering and reliable performance.
Steering cylinder: two action cylinders

Steering type	Steering wheel
Steering pressure	16 MPa
Number of cylinders	2
Diameter of cylinder bore	100 mm
Diameter of piston rod	55 mm
Travel of cylinder	324 mm
Displacement of pump	80 ml/r
Steering angle	±35°
Min. steering (outside of tire)	6,980 mm

Cab

Description

The Jingong new KV luxury cab is equipped with heating and cooling air-conditioning, adjustable directional column and sunshade, fire extinguisher, safety hammer, adjustable seat, USB charging, etc., which greatly improves driving comfort.

The left side of the cab enters unilaterally, the door opens forward, and the width of the exit is increased by 20%. There is no threshold design, which is more convenient for drivers to going and out; The right window is equipped with a glass frame that can be pushed up and down; The front window of cab is hyperboloid toughened glass, which has wide visual field and good sound insulation performance. The cab adopts four-point elastic suspension and two-way shock absorption; Used sound-absorbing materials to reduce noise, and used floor mats for sound insulation, which reduced indoor noise.

Noise & Air conditioner

Cab noise In line with ISO 6396-2008 / EN ISO 3744-1995	83 dB(A)-- Travel mode
Cab noise In line with ISO 6396-2008 / EN ISO 3744-1995	84 dB(A)--Stationary work cycle mode
Outdoor noise In line with ISO 6395-2008	110 dB(A)--Travel mode
Outdoor noise In line with ISO 6395-2008	111 dB(A)--Stationary work cycle mode
Heating capacity of A/C	5 kW (7.8 hp)
Refrigerating capacity of A/C	4.7 kW (8 hp)

Electronic system

Description

GPS (Global Positioning System)
Brand-new intelligent instrument system is able to monitor the real-time work conditions of complete vehicle.
Updated smart control system with independent intellectual property has the remote diagnosis system which could provide the fast and accurate solution to customer in case of failure
Reversing alarm could make the driving safer.

Voltage	24 V
Battery	2 x 12 V
Battery capacity	2 x 120Ah
Capacity of cold startup	850 A
Reserve capacity	230 min
Grade of AC generator	1,960 W / 70 A
Output of starter motor	7.5 kW

Performance parameters

Description

Tilting load is calculated with standard bucket of 4 m³ and 21000kg of operation weight.

Tipping load - straight according to ISO 14397-1:2007	12,400 kg
Tilting load – full turning in line with ISO 14397-1:2007	11,000 kg
Breakout force	>200 kN
A Pivot height at max. lifting height	4,373 mm
B Unloading height	3,215 mm
C Unloading height at max. lifting height	1,165 mm
D Breakout depth	50 mm
S1 Max. bucket-withdrawing angle on the ground	45°
S2 Max. bucket-withdrawing angle at transporting position	48°
S3 Max. bucket-withdrawing angle at max. lifting height	53°
S4 Unloading angle	45°

Dimensions

E Ground clearance	487 mm
G Wheelbase	3,470 mm
H Cab height	3,560 mm
J Wheel track	2,268 mm
K Outside width of tire	2,953 mm
L Overall length (with the attachments)	8,380 mm
M Steering angle, at any side	35°
P Departure angle	32°
R1 Min. turning radius with bucket at transporting position	7,635 mm
R2 Turning radius, at outside of tire	6,980 mm

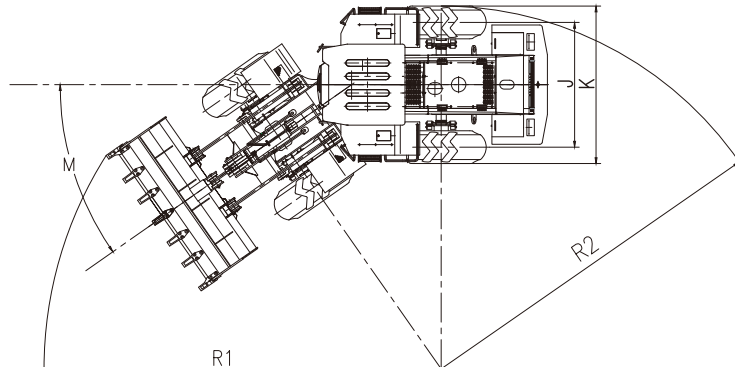
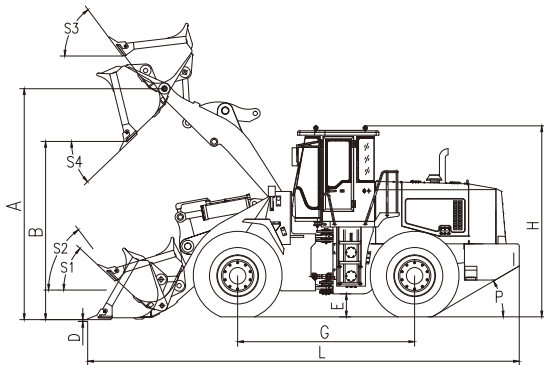

Tire

Proper tires for your machine will become the key competitive edge of excellent performance. Through closely and jointly development and cooperation with well-known supplier which is carefully selected, Jingong could provide the full-series tires specially customized for wheeled loader.

Size	Application	Mode	Dimensions	PR/*	Tube type	Width	Overall diameter	Depth of tread	Loading capacity, 50km/h/10km/h
L2	<ul style="list-style-type: none"> At site with good traction For example, on slope with smooth gradeability Work at soft and muddy site without sharp rocks. In all loading/transporting conditions. 		26.5-25	16	TL	675mm	1,750mm	29.5mm	7,300/11,500kg
			26.5-25	20	TL	675mm	1,750mm	29.5mm	8,250/9,500kg
L3	<ul style="list-style-type: none"> Work in sandy conditions In all types of loading/carrying operations Unlike L2, L3 tread is narrow and less self-cleaning effect. 		26.5-25	24	TL	675mm	1,750mm	35mm	9,050/14,000kg
			26.5-25	28	TL	675mm	1,750mm	35mm	10,000/15,500kg
			26.5-25	32	TL	675mm	1,750mm	35mm	11,200/17,000kg
			26.5R25	*	TL	675mm	1,750mm	36mm	9,000/15,000kg
			26.5R25	**	TL	675mm	1,750mm	36mm	11,500/18,500kg

Note: radial tire has its load-bearing capacity represented with stars *. The more stars means the radial tire has more load-bearing capacity. The special radial tire dimensions listed in table 2 starts (**) means the max. load-bearing capacity of radial tire.

Parameters of work equipments

Item	Rock bucket	General bucket	Coal bucket	High-position unloading			Unit
				Regular bucket	Coal bucket	Enlarged bucket	
Bucket capacity	3.3	4	4.5	3.5	4.5	5.5	m ³
Rated load	6000	6000	6000	5500	5500	5500	kg
Complete vehicle weight	21100	21200	21220	21600	21820	21920	kg
Unloading height	3250	3135	3115	3565	3485	3450	mm
Unloading distance	1150	1180	1205	1450	1575	1610	mm
Overall length	8254	8520	8520	8816	8953	9150	mm
Min. steering radius (edge of bucket)	7540	7825	7825	8035	8130	8250	mm

The product structures and parameters may alter with the technology updating, without any notice in advance. If sample differs from the actual product, the latter prevails.

Standard configurations

Engine

Cummins :6LTAA8.9-C240(T2)
Engine output power 179KW
Oil-bathed dual-layer air filter
(reinforced radiating system and filter for desert area)

Drive

Planetary – type power-assisted transmission from Chinese Advance Transmission(ZF Technology)
Startup function, forward four gears, neutral gear and backward two gear
Transmission oil level detector
Secondary oil filter, oil bar

Drive axle

USA meritor axle
Hydraulic – pliers disc type break
Clamp disc parking brake

Hydraulic system

Joystick control
Dual-pump confluence hydraulic system

Steering system

Full-hydraulic coaxial flow-amplification steering system and steering – prevailing

Tire

26.5-25 / L3 diagonal tire
Regular mudguard

Frame assembly

Spacious central articulation arrangement with conic bearing
Articulated locking lever
Draw bar

Electrical system

Two headlamps, low beam/ high beam
On the top of cab, there are two headlamps
Battery, maintenance-free
24 V power socket
Electric horn
Wiper of windshield
Radio / player with USB port
Reversing warning lamp
Heating/cooling A/C

Instrument

Engine coolant temperature
Transmission oil temperature
Fuel level meter
Timer
Voltage
Brake pressure
Charging of battery
Steering lamp
Transmission oil pressure alarm
High-beam indicator

Cab

Seat
Dual-direction adjustable steering column
Large- arc window
Rubber cushion
Two sides of rearview mirror
One cup holder
Sunvisor

Others

On-board tools and attachments

Optional configurations

Engine

Cummins engine Tire III
Weichai engine TireII or Tire III
Oil-bathed dual-layer air filter

Hydraulic system

Flexible shaft operation

Axles and tires

Check the front tire specifications
Tire protective chains

Transmission

DANA transmission

Others

Automatic central lubrication
Automatic weighing device
Sub blade

Cab

Luxury seat

WIN WITH RELIABILITY



子江集团 • 福建晋工机械有限公司
Fujian Jingong Machinery Co., Ltd.

地址: 中国福建省晋江市安海前埔工业区
ADD: Anhai Qianpu Industrial Zone, Jinjiang City Fujian Province China
服务电话/Service Phone: 400-0922-789
邮编/Postcode: 362261

网址/Website: www.jingong-china.com.cn
邮箱/E-mail: overseas@china-jingong.com

The contents and specifications of this brochure are subject to change without prior notice.
The pictures in this brochure may differ from the actual machines sold.