



品质创造价值

QUALITY CREATES VALUE



DX400PC-9
山东鹏程斗鑫机械有限公司

履带式液压挖掘机
Crawler hydraulic Excavator

Product features:

- Adopt Cummins/ISUZU high-quality turbo-charged engine, which is a fuel-efficient low-emission engine
- Advanced Kawasaki hydraulic system with excellent performance, reasonable match, and reliable quality
- Travel motor: DOOSAN
- Swing motor: Kawasaki
- Powerful travel traction
- Effectively prevent mixing of soil and rock
- The machine can finish all tasks that the driver wants and the highest working efficiency among the same tonnage products in the industry.
- Main structural parts including the boom, arm, bucket and the chassis are built by welding the new, high-strength structural parts together, to increase the strength of the structural and their service life.
- Safe and open engine hood
- Convenient and swift maintenance

Performance parameters

Weight	37.8T
Bucket capacity	1.9m ³
Engine rated power	214 (287)kw
Swing speed	8.2min ⁻¹
Travel speed (high/low)	4.9-2.9km/h
Ground specific pressure	0.69kg/cm ²
Gradeability (%)	70
Digging force	240KN
Implement Circuits	31.4mpa
Power Boost	34.3mpa
Swing Circuits	29.4mpa
Travel Circuits	34.3mpa
Max. Rated Flow of main pumps	2X282l/min
Boom length	6500mm
Arm length	2902mm

Working range

Maximum digging depth	7135mm
Maximum digging height	10100mm
Maximum unloading height	7180mm
Maximum digging radius	10635mm
Minimum turning radius	4485mm

Dimensions

a	Transport length	11380mm
b	Transport arm height	3720mm
c	Tumblers distance	4050mm
d	Radius of gyration platform end	3530mm
e	Counter weight ground clearance	1250mm
f	Track gauge	2750mm
g	Total width of undercarriage	3350mm
h	Width of upper structure	3155mm
i	Width of track shoe	600mm
j	Ground clearance	545mm
k	Total length of travel mechanism	4975mm
l	Total width of cabin	1035mm
m	Cabin height	835mm

Working range diagram

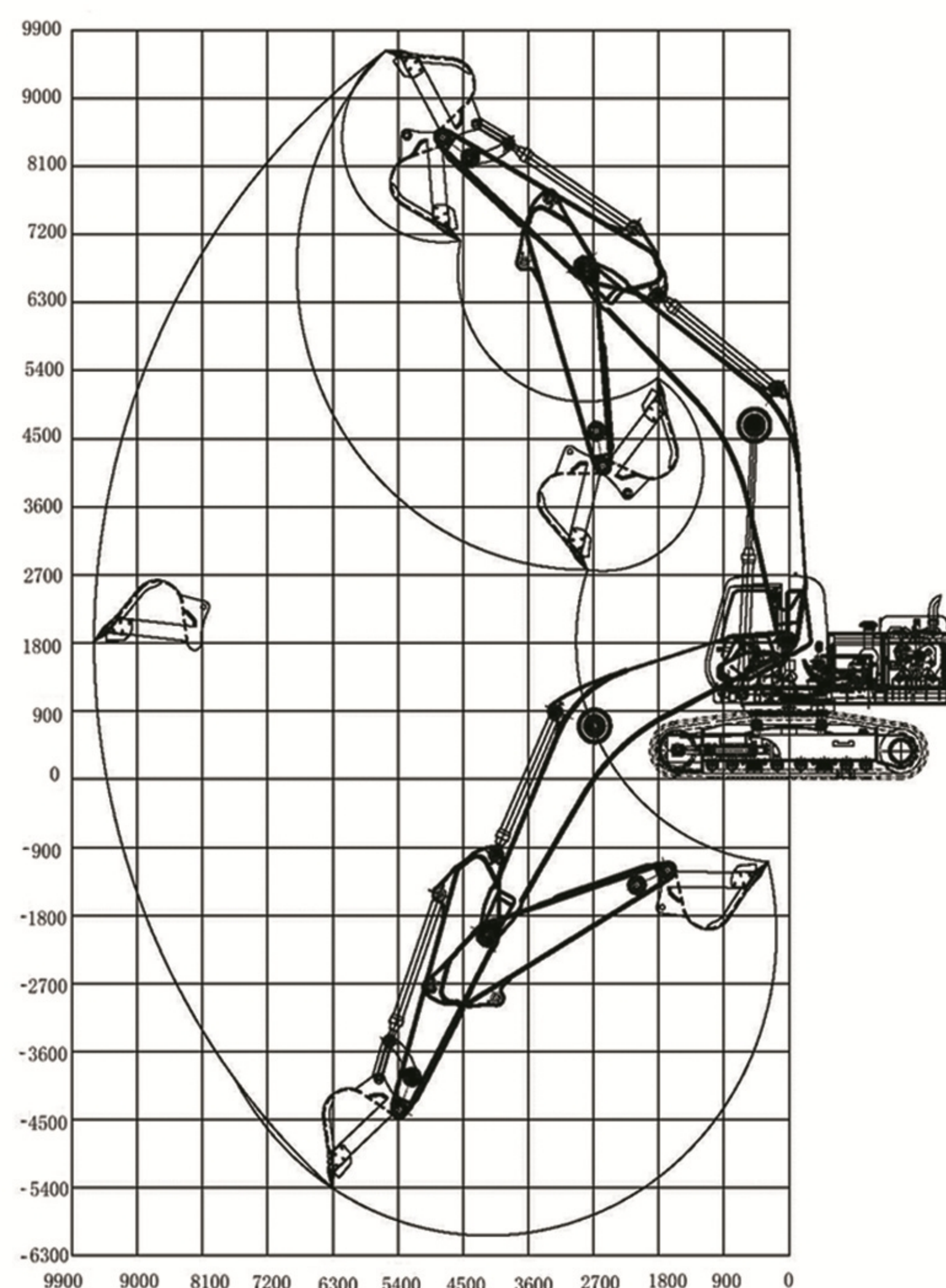

Dimensions diagram

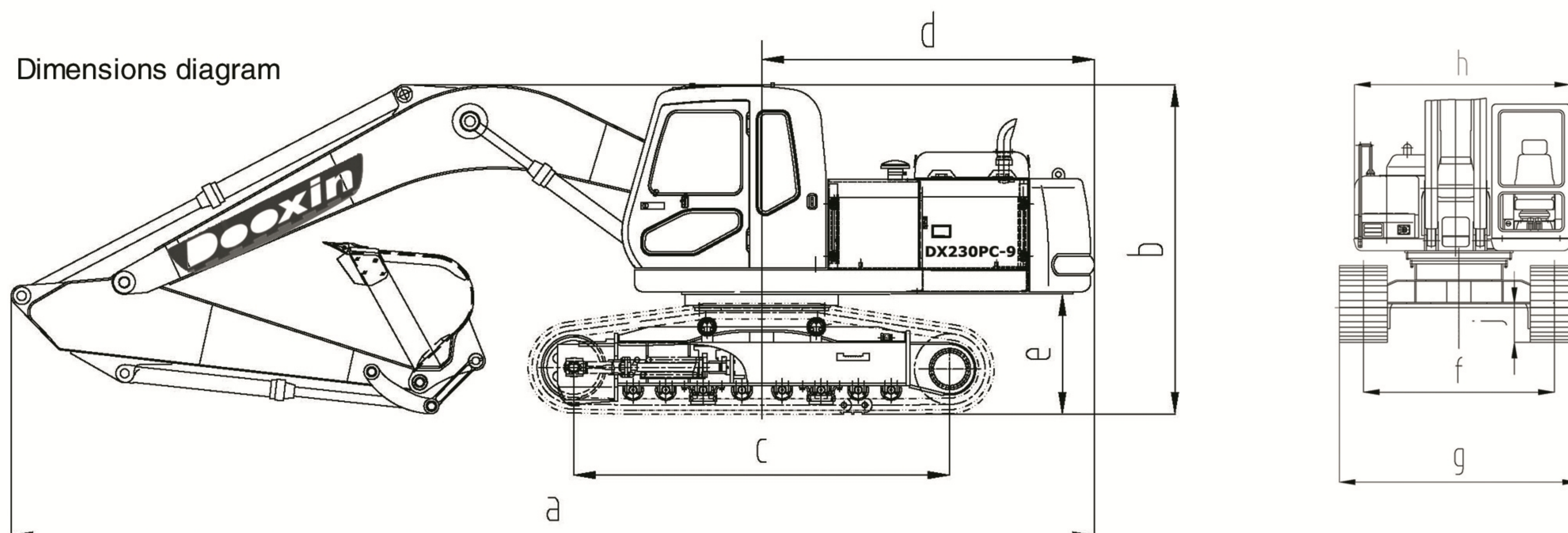

鹏程斗鑫

Shandong Pengcheng Dooxin Construction Machinery Co., Ltd.
Add: 418 Duoshan Road, Muping District, Yantai, Shandong Province, P. R. China
www.shandongpengcheng.com